



*Platinum*  
VISUAL SOLUTIONS



# Product Guide



**DELIVERING ON OUR PROMISES FOR OVER 60 YEARS!**



**DTS Markerboard**



**Vertical Sliding Markerboard**



**Edge-Wrapped Tackboard**



**SOLUTIONS FOR ALL FOUR WALLS**

*From corner to corner, we're here to make your space awesome!*



**THE MOST DEPENDABLE BRAND IN EDUCATION**

*We always have your back!*



**WORRY-FREE DELIVERY**

*Like a protective parent, we get your stuff from point A to point B without a scratch.*



**UNRIVALED CUSTOMER SERVICE**

*We're in a class of our own.*



**COAST-TO-COAST MANUFACTURING**

*From PA to CA we've got you covered!*





## ABOUT US:

For over 60 years, Platinum Visual Solutions has been at the forefront of solving classroom design challenges. We are dedicated to simplifying the teaching experience and fostering creativity and innovation in education. More than just a manufacturer, we offer tailored solutions to meet your unique needs in learning and collaboration spaces.

We're excited about our partnership with Educator's Depot, Inc., and the Platinum team is fully committed to supporting Educator's mission of creating Prosocial Learning Environments.

We're here to make it easy for you to elevate your educational spaces—please let us know how we can assist!

For quotes and inquiries,  
contact:

**Educator's Depot, Inc.**

**TEL** 866.736.2012

**EMAIL** [customerservice@educatorsdepot.com](mailto:customerservice@educatorsdepot.com)

# Drop-In Tray System Boards (DTS)

- Writanium® porcelain writing surfaces are projection-friendly, accept magnetic accessories, and resist ghosting or staining.
- Backed by our forever warranty for lasting peace of mind.
- All extrusions are manufactured with high quality aluminum alloy to exacting specifications.
- Heavy-duty aluminum extrusions come standard in a clear satin anodized finish, with optional upgrades to a variety of powder-coated finishes.
- All tackable surfaces ship fully framed and include hardware for installation.
- Custom sizes available.

## MARKERBOARD (W/1" MAP RAIL)

MODEL	SIZE (HxW)
800130400	3' x 4'
800140400	4' x 4'
800140500	4' x 5'
800140600	4' x 6'
800140800	4' x 8'
800141000	4' x 10'
800141200	4' x 12'
800141600	4' x 16'
800150800	5' x 8'
800151000	5' x 10'
800151200	5' x 12'
800151600	5' x 16'

## MARKERBOARD (W/NO MAP RAIL)

MODEL	SIZE (HxW)
800030400	3' x 4'
800040400	4' x 4'
800040500	4' x 5'
800040600	4' x 6'
800040800	4' x 8'
800041000	4' x 10'
800041200	4' x 12'
800041600	4' x 16'
800050800	5' x 8'
800051000	5' x 10'
800051200	5' x 12'
800051600	5' x 16'

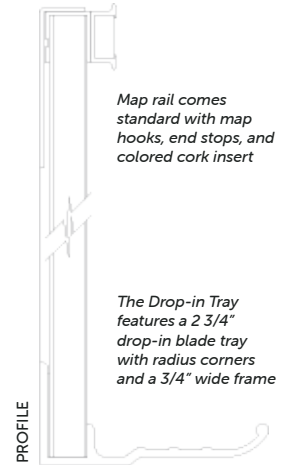

Markerboards are available with graphics/music staff.  
Please contact your Customer Service Representative for a quote.



Platinum boards meet the gold level indoor air quality environmental standards of the Scientific Certification Systems

**COLORED CORK TACKBOARD**

(1/4" CORK ON 1/4" DURABLE SUBSTRATE)

MODEL	SIZE (HxW)
8006304XX	3' x 4'
8006404XX	4' x 4'
8006405XX	4' x 5'
8006406XX	4' x 6'
8006408XX	4' x 8'
8006410XX	4' x 10'
8006412XX	4' x 12'

PROFILE



COLORED CORK TACKBOARDS

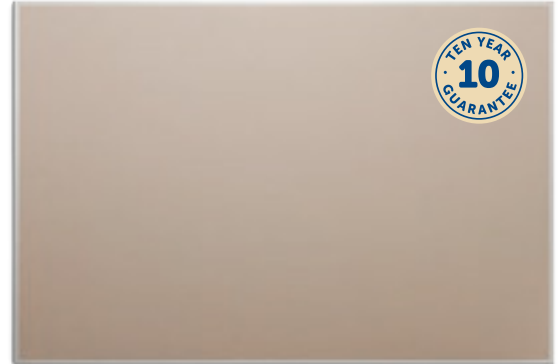

**VINYL ON STANDARD TACKBOARD**

(1/2" LIGHTWEIGHT SUBSTRATE)

MODEL	SIZE (HxW)
8007304XX	3' x 4'
8007404XX	4' x 4'
8007405XX	4' x 5'
8007406XX	4' x 6'
8007408XX	4' x 8'
8007410XX	4' x 10'
8007412XX	4' x 12'

**VINYL ON PREMIUM TACKBOARD**

(1/8" CORK + 3/8" LIGHTWEIGHT SUBSTRATE)

MODEL	SIZE (HxW)
8008304XX	3' x 4'
8008404XX	4' x 4'
8008405XX	4' x 5'
8008406XX	4' x 6'
8008408XX	4' x 8'
8008410XX	4' x 10'
8008412XX	4' x 12'

VINYL TACKBOARDS

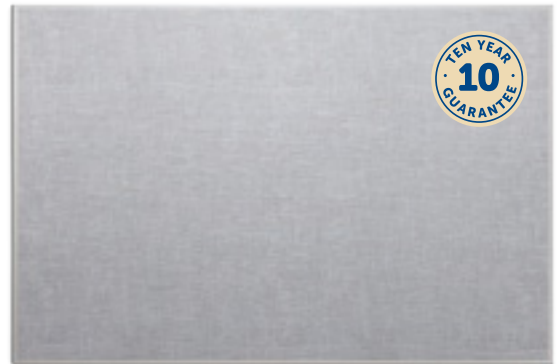

**FABRIC ON STANDARD TACKBOARD**

(1/2" LIGHTWEIGHT SUBSTRATE)

MODEL	SIZE (HxW)
8010304XX	3' x 4'
8010404XX	4' x 4'
8010405XX	4' x 5'
8010406XX	4' x 6'
8010408XX	4' x 8'
8010410XX	4' x 10'
8010412XX	4' x 12'

**FABRIC ON PREMIUM TACKBOARD**

(1/8" CORK + 3/8" LIGHTWEIGHT SUBSTRATE)

MODEL	SIZE (HxW)
8011304XX	3' x 4'
8011404XX	4' x 4'
8011405XX	4' x 5'
8011406XX	4' x 6'
8011408XX	4' x 8'
8011410XX	4' x 10'
8011412XX	4' x 12'

FABRIC TACKBOARDS

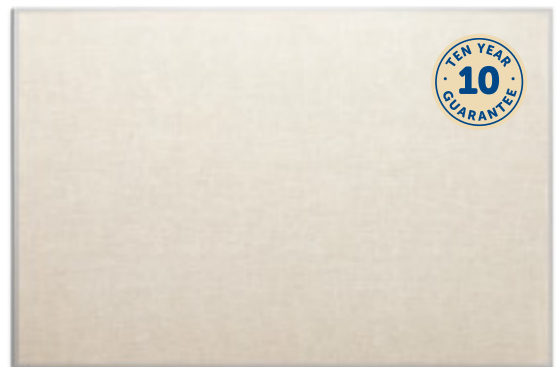

**PREMIUM NATURAL CORK TACKBOARD**

(1/8" NATURAL CORK + 3/8" LIGHTWEIGHT SUBSTRATE)

MODEL	SIZE (HxW)
801330499	3' x 4'
801340499	4' x 4'
801340599	4' x 5'
801340699	4' x 6'
801340899	4' x 8'
801341099	4' x 10'
801341299	4' x 12'

NATURAL CORK TACKBOARDS



# Box Tray System (BTS)

- Writanium® porcelain writing surfaces are projection-friendly, accept magnetic accessories, and resist ghosting or staining.
- Backed by our forever warranty for lasting peace of mind.
- All extrusions are manufactured with high quality aluminum alloy to exacting specifications.
- Heavy-duty aluminum extrusions come standard in a clear satin anodized finish, with optional upgrades to a variety of powder-coated finishes.
- Full length extruded aluminum box tray with cast aluminum end closures.
- All tackable surfaces ship fully framed and include hardware for installation.
- Custom sizes available.

## MARKERBOARD (W/1" MAP RAIL)

MODEL	SIZE (HxW)
802130400	3' x 4'
802140400	4' x 4'
802140500	4' x 5'
802140600	4' x 6'
802140800	4' x 8'
802141000	4' x 10'
802141200	4' x 12'
802141600	4' x 16'
802150800	5' x 8'
802151000	5' x 10'
802151200	5' x 12'
802151600	5' x 16'

## MARKERBOARD (W/NO MAP RAIL)

MODEL	SIZE (HxW)
802030400	3' x 4'
802040400	4' x 4'
802040500	4' x 5'
802040600	4' x 6'
802040800	4' x 8'
802041000	4' x 10'
802041200	4' x 12'
802041600	4' x 16'
802050800	5' x 8'
802051000	5' x 10'
802051200	5' x 12'
802051600	5' x 16'

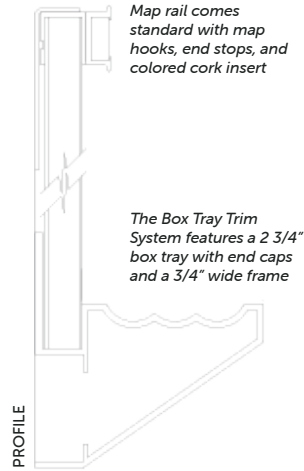

Platinum boards meet the gold level indoor air quality environmental standards of the Scientific Certification Systems

# Retrofit Markerboards

**Good as new.** For classrooms, businesses and other institutions with old, faded, scratched or worn markerboards or chalkboards, retrofitting with Platinum's superior advanced surface replacement technology can be the simplest, best and most economic solution. Our customized panels fit easily over old boards to update a pre-existing structure without the hassle of removing it. New retrofit non-reflective surfaces offer smooth writing and clean erasure with no glare or ghosting.

- For resurfacing markerboards or chalkboards.
- Extrusions come in standard clear satin anodized.
- Pre-drilled holes in the aluminum frame help speed installation.
- Writanium® porcelain writing surfaces are projection-friendly, accept magnetic accessories, and resist ghosting or staining.
- Backed by our forever warranty for lasting peace of mind.
- Designed to be installed over existing surfaces.
- Can be used with wood or aluminum trim finishes.

## FACE-MOUNTED RETROFIT MARKERBOARDS

MODEL	SIZE (HxW)
854940400	4' x 4'
854940600	4' x 6'
854940800	4' x 8'
854941000	4' x 10'
854941200	4' x 12'
854941600	4' x 16'





# Maximize your wall space.



Platinum boards meet the gold level indoor air quality environmental standards of the Scientific Certification Systems



# Floor to Ceiling Markerboards (FCS)

**Think Big.** Get creative with our FCS Writanium® porcelain marker wall, offering endless possibilities for your space. We design and manufacture oversized panels to be joined together using a concealed stabilizing spline, creating a smooth transition from panel to panel. Sizes range from 6' high by 8' wide, up to a massive 12' high by 24' wide wall system. Our team can also custom design and manufacture panels to fit any size room.

- The ideal solution for applications that require the absolute maximum amount of writing space.
- Writanium® porcelain writing surfaces are projection-friendly, accept magnetic accessories, and resist ghosting or staining.
- Backed by our forever warranty for lasting peace of mind.
- Panels come in sizes up to 4'x12' and are joined with a concealed spline butt joint.
- All extrusions are manufactured with high quality aluminum alloy to exacting specifications.
- Designed to fit any size room.
- Custom configurations are fabricated utilizing 48" W center panel(s) with balanced ends.
- Please note: Overall dimensions are increased by 7/8" (H & W) to accommodate panel installation. For example #815081200, actual dimensions are 96-7/8" H x 144-7/8" W.

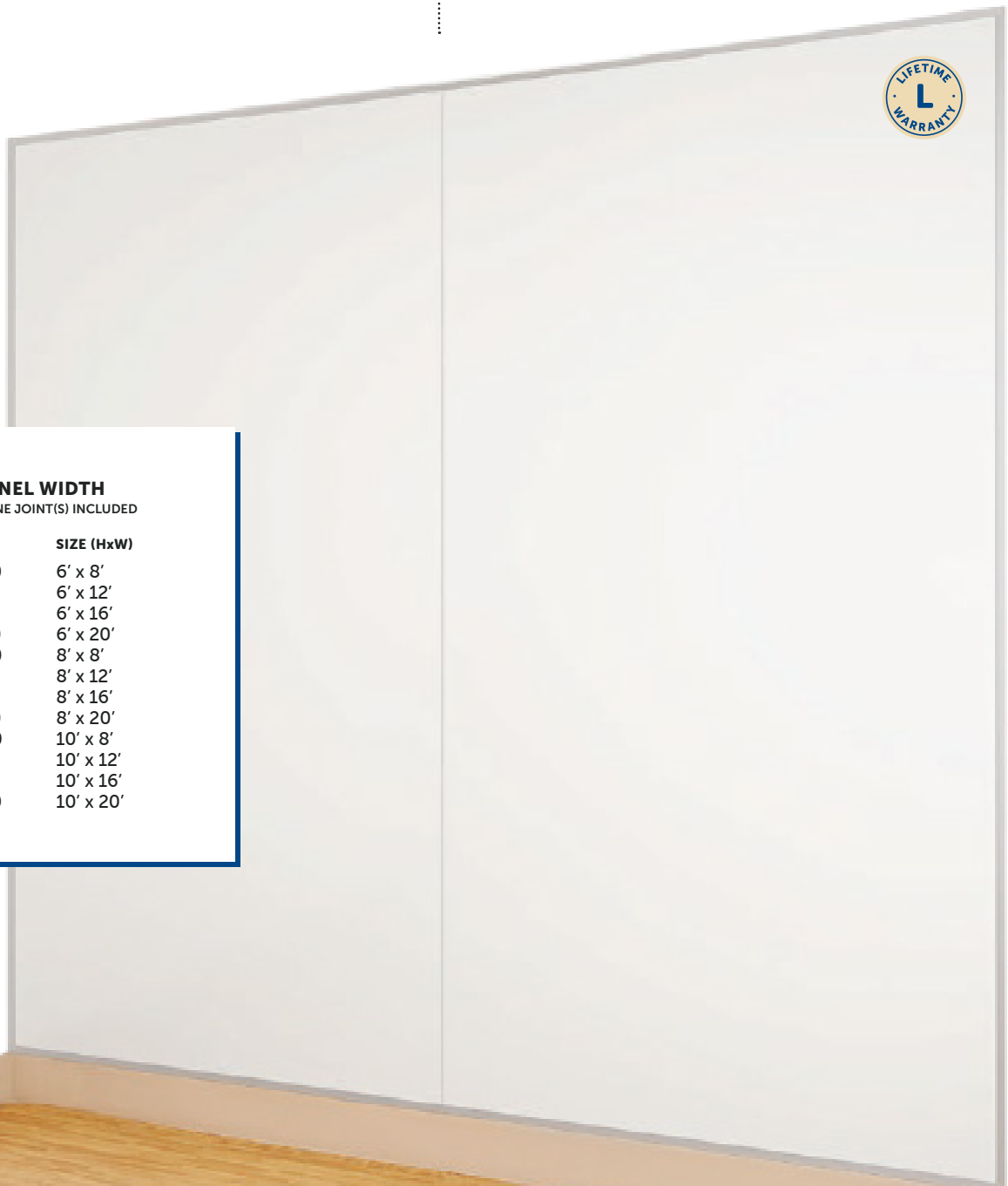

## EQUAL PANEL WIDTH TRIM AND SPLINE JOINT(S) INCLUDED

MODEL	SIZE (HxW)
815060800	6' x 8'
815061200	6' x 12'
815061600	6' x 16'
815062000	6' x 20'
815080800	8' x 8'
815081200	8' x 12'
815081600	8' x 16'
815082000	8' x 20'
815000800	10' x 8'
815001200	10' x 12'
815001600	10' x 16'
815002000	10' x 20'

# Wall Mounted Horizontal Sliding Units

Slide into space. Flex your workspace muscle and maximize visual communication with a customized Wall Mounted Horizontal Sliding Unit. Double or triple the amount of usable surface with a minimum of wall space. We'll help you design a unit with your choice of writing or tackable surfaces and colors.

## **2 TRACKS & 2 HALF WIDTH PANELS** WITH FULL BACK PANEL

MODEL	SIZE (HxW)
817840800	4' x 8'
817841000	4' x 10'
817841200	4' x 12'
817841600	4' x 16'

## **3 TRACKS & 3 HALF WIDTH PANELS** WITH FULL BACK PANEL

MODEL	SIZE (HxW)
818240800	4' x 8'
818241000	4' x 10'
818241200	4' x 12'
818241600	4' x 16'



*Shown: WHS2 Track  
Horizontal Sliding Unit*

# Vertical Sliding Units



Standard with finished kick panel

**Keep up the space.** Our Vertical Sliding Units maximize visual communication and save workspace in even the tightest spots. Perfectly counter-balanced weights allow you to raise or lower one or more sliding panels in a smooth, easy motion. As with our horizontal units, you can choose from any combination of writing or tackable surfaces and colors.

- Writanium® porcelain writing surfaces are projection-friendly, accept magnetic accessories, and resist ghosting or staining.
- Backed by our forever warranty for lasting peace of mind.

## Floor Mounted Vertical Sliding Unit (FVS)

**2 TRACKS & 2 HALF HEIGHT PANELS**  
WITH FULL BACK PANEL & MATCHING KICK PANEL

MODEL	SIZE (HxW)
819610800	10' x 8'
819610000	10' x 10'
819610200	10' x 12'

## Wall Mounted Vertical Sliding Unit (WVS)

**2 TRACKS & 2 HALF HEIGHT PANELS**  
WITH FULL BACK PANEL

MODEL	SIZE (HxW)
818780800	8' x 8'
818781000	8' x 10'
818781200	8' x 12'

Heavy duty pulley system makes sliding panels effortless



Platinum boards meet the gold level indoor air quality environmental standards of the Scientific Certification Systems

# Brilliant Glass Magnetic Glassboards

A clear visionary. The Brilliant Glass glassboards feature a premium, ultra-clear, low-iron writing surface that provides lasting clarity while enhancing any environment with its sleek, modern design. Available in 2 different mounting style options. Glass surface will not ghost or stain and is made from tempered glass with a steel backing built to last.

- (5) Standard Sizes
- (2) Mounting Options
- Magnetic Glass



P-100 WHITE  
(STANDARD)

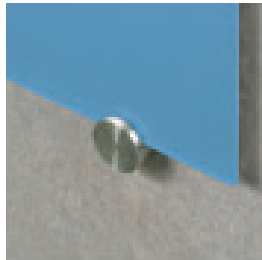

## FLUSHMOUNT "PUCKS"

MODEL	SIZE (HxW)
860030400	3' x 4'
860040400	4' x 4'
860040500	4' x 5'
860040600	4' x 6'
860040800	4' x 8'



## WALLMOUNT "VERSIMOUNT"

MODEL	SIZE (HxW)
860230400	3' x 4'
860240400	4' x 4'
860240500	4' x 5'
860240600	4' x 6'
860240800	4' x 8'



## Brilliant Glass Accessories



### BRILLIANT GLASS ERASER W/LOGO

MODEL ACC-GLS ERASER



### BRILLIANT GLASS MAGNET, ROUND W/LOGO

MODEL ACC-GLS MAGNET



### BRILLIANT GLASS ACCESSORY KIT INCLUDES: ERASER, PEN CUP, & 8 MAGNETS

MODEL ACC-GLS KIT

# Contrasting Color Selections

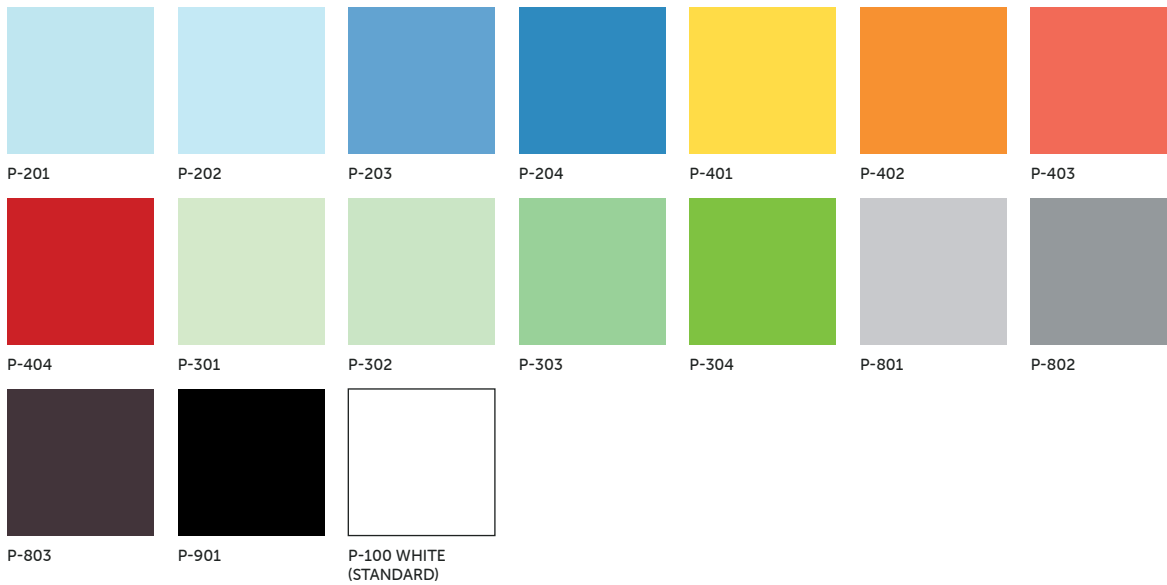

*\*Glassboards are available in custom options and custom graphics.  
Please contact your Customer Service Representative for a quote.*



# Glaswrite MobileMate™ Magnetic Glassboards

On the move. Add style to any classroom, office space or medical facility with Platinum's, exquisite Glaswrite MobileMate™. Available in magnetic and non-magnetic glass with nesting, perfect for easy mobility!

- Available in Magnetic & Non-Magnetic Glass
- Nesting for Easy Mobility
- (3) Standard Sizes
- P-100 Frosted White Standard

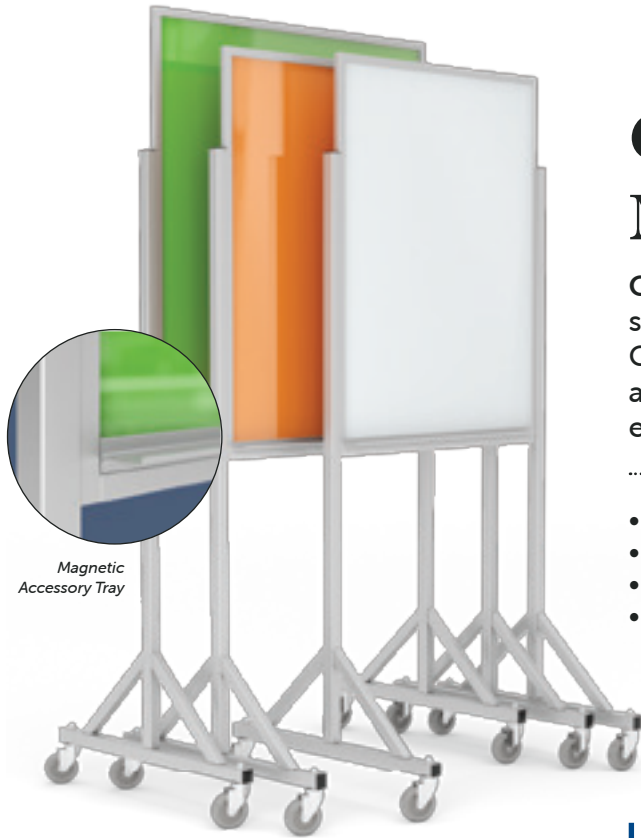

Magnetic  
Accessory Tray

## EASEL (MAGNETIC)

MODEL	SIZE (HxW)
8607GWMMM	72" x 30"
8609GWMMM	72" x 36"



Durable casters

## Glaswrite MobileMate™ Room Divider with Tackable Bottom Panel

### VINYL BOTTOM

MODEL	SIZE (HxW)
8604GWMMXX	60" x 30"
8606GWMMXX	60" x 36"

### FORBO BOTTOM

MODEL	SIZE (HxW)
8605GWMMXX	60" x 30"
8607GWMMXX	60" x 36"



Quality frame construction keeps writing surface steady

### FIXED ROLL-RITE

MODEL	SIZE (HxW)
825140500	4' x 5'
825140600	4' x 6'
825140800	4' x 8'
825240599	4' x 5'
825240699	4' x 6'
825240899	4' x 8'
8253405XX	4' x 5'
8253406XX	4' x 6'
8253408XX	4' x 8'

8251=MARKERBOARD ON BOTH PANELS  
 8252=MARKERBOARD/NATURAL CORK BULLETIN BOARD  
 8253=MARKERBOARD/VINYL COVERED BULLETIN BOARD

# Platinum Roll-Rite

A double board to go. When two boards are better than one – and you need them on the move, our Platinum Roll-Rites are your ticket to write. These reversible boards rotate to provide your choice of two surfaces from our extensive variety of exceptional chalkboards, markerboards and tackboards. You can even custom imprint graphics including music staff lines, logos and graphs.

- Porcelain-on-steel, magnetic writing surfaces.
- Double-sided board rotates 360° and locks for a quick turnaround.
- Moves on rolling base designed for stability and features locking casters.
- Clear satin anodized aluminum frame with full-length accessory tray.
- 10 year guarantee on all tackboard surfaces.
- Lifetime warranty on Writanium® surfaces.
- Overall height: 72".

Board locks easily into place with tightening knobs

### REVOLVING ROLL-RITE

MODEL	SIZE (HxW)
825640500	4' x 5'
825640600	4' x 6'
825640800	4' x 8'
825740599	4' x 5'
825740699	4' x 6'
825740899	4' x 8'
8258405XX	4' x 5'
8258406XX	4' x 6'
8258408XX	4' x 8'

8256=MARKERBOARD ON BOTH PANELS  
 8257=MARKERBOARD/NATURAL CORK BULLETIN BOARD  
 8258=MARKERBOARD/VINYL COVERED BULLETIN BOARD



Locking heavy duty casters are durable and keep board from moving when writing

# Premium Series Roll-Rite Room Dividers

Divide and conquer. Platinum Premium Roll-Rite Room Dividers allow you to segregate space and create privacy zones, quickly and easily. We designed our heavy-duty 16-guaged gusseted frames with four 3" swivel ball-bearing casters, two locking and two non-locking, to provide stability and ease of movement.

- Available in anodized or powder coated finish.
- Choose from multiple panel configurations.
- Surface options for panels include porcelain steel Writanium® markerboard, designer vinyl or fabric.



WRITANIUM®  
MARKERBOARD



DESIGNER VINYL

## ROLL-RITE ROOM DIVIDERS

MODEL	SIZE (HxW)
826260500	6' x 5'
826260600	6' x 6'
826260800	6' x 8'
8264605XX	6' x 5'
8264606XX	6' x 6'
8264608XX	6' x 8'
8265605XX	6' x 5'
8265606XX	6' x 6'
8265608XX	6' x 8'

8262=MARKERBOARD ON BOTH PANELS  
8264=MARKERBOARD/VINYL COVERED BULLETIN BOARD  
8265=MARKERBOARD/FABRIC COVERED BULLETIN BOARD



FABRIC



Platinum boards meet the gold level indoor air quality environmental standards of the Scientific Certification Systems



# Bulletin and Directory Boards

Information on board. Choose from any of our tackable surfaces to create bulletin or directory boards, available in your choice of hinged or sliding door designs with our high-quality 1/4" tempered glass. Add a grooved panel to create a directory. We'll fully assemble each case for you in advance and ship it ready to hang.

- A simple, elegant display for bulletin and directory boards.
- Heavy duty aluminum extrusions come standard in clear satin anodized.
- Also available in optional dark bronze anodized or a variety of powder coated finishes.

## Sliding Glass Bulletin and Directory Case (SBS)

Standard depth: 3"



### 2 SLIDING DOORS BULLETIN WITH LOCK

MODEL	SIZE (HxWxD)
8235404XX	4' x 4' x 3"
8235406XX	4' x 6' x 3"
8235408XX	4' x 8' x 3"



### 2 SLIDING DOORS DIRECTORY WITH LOCK

MODEL	SIZE (HxWxD)
8236404XX	4' x 4' x 3"
8236406XX	4' x 6' x 3"
8236408XX	4' x 8' x 3"



Premium quality locking mechanism keeps content secure



DIRECTORY BOARD



BULLETIN BOARD

## Hinged Door and Directory Case (HBS)

### 1 HINGED DOOR BULLETIN WITH LOCK

MODEL	SIZE (HxWxD)
8221203XX	2' x 3' x 3"
8221303XX	3' x 3' x 3"

### 2 HINGED DOORS BULLETIN WITH LOCK

MODEL	SIZE (HxWxD)
8222404XX	4' x 4' x 3"
8222406XX	4' x 6' x 3"
8222408XX	4' x 8' x 3"

### 3 HINGED DOORS BULLETIN WITH LOCK

MODEL	SIZE (HxWxD)
8223408XX	4' x 8' x 3"

### 4 HINGED DOORS BULLETIN WITH LOCK

MODEL	SIZE (HxWxD)
8224408XX	4' x 8' x 3"

### 1 HINGED DOOR DIRECTORY WITH LOCK

MODEL	SIZE (HxWxD)
8225203XX	2' x 3' x 3"
8225303XX	3' x 3' x 3"

### 2 HINGED DOORS DIRECTORY WITH LOCK

MODEL	SIZE (HxWxD)
8226404XX	4' x 4' x 3"
8226406XX	4' x 6' x 3"
8226408XX	4' x 8' x 3"

### 4 HINGED DOORS DIRECTORY WITH LOCK

MODEL	SIZE (HxWxD)
8228408XX	4' x 8' x 3"

Standard depth: 3"



## Free Standing Trophy and Display Case with Wood Base and Upper Cornice (FWS)

MODEL	SIZE (HxWxD)
8238604XX	6' x 4' x 12"
8238606XX	6' x 6' x 12"
8238608XX	6' x 8' x 12"

Standard depth: 12"  
Note: display cases are standard in Birch  
veneer plywood with clear finish.

Tempered glass shelves  
hold up to 100 pounds



Premium quality locking mechanism keeps content secure

## Trophy and Display Case with Hinged Glass Doors (HWS)

### 2 HINGED DOORS

WITH LOCK

MODEL	SIZE (HxWxD)
8233404XX	4' x 4' x 12"
8233406XX	4' x 6' x 12"

### 3 HINGED DOORS

WITH LOCK

MODEL	SIZE (HxWxD)
8234408XX	4' x 8' x 12"

Standard depth: 12"

Note: display cases are standard in Birch veneer plywood with clear finish.

 **CUSTOM SIZES AVAILABLE.**  
PLEASE CALL US AT 800-498-2990 FOR DETAILS



## Trophy and Display Case with Sliding Glass Doors (SWS)

MODEL	SIZE (HxWxD)
8237404XX	4' x 4' x 12"
8237406XX	4' x 6' x 12"
8237408XX	4' x 8' x 12"

Standard depth: 12"

Note: display cases are standard in Birch veneer plywood with clear finish.

 **CUSTOM SIZES AVAILABLE.**  
PLEASE CALL US AT 800-498-2990 FOR DETAILS

# Platinum Envirotack™ Tackboards

**Earth saver.** We produce our eco-friendly Platinum Envirotack™ from high quality, recycled rubber and virgin rubber material, reducing oil consumption and keeping millions of pounds of rubber waste out of landfills. Our recyclable Platinum Envirotack also meets indoor air quality and VOC emission requirements — and is free of urea-formaldehyde — making it people and planet-friendly.

- Manufactured with 1/8" thick rubber permanently bonded to 3/8" industrial grade substrate.
- Resists moisture, mold and mildew.
- Non-fading and stain-resistant.
- Available in standard size panels and extended length rolls.

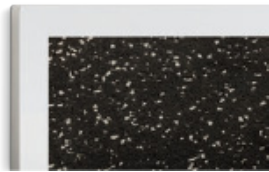

BLACK + WHITE

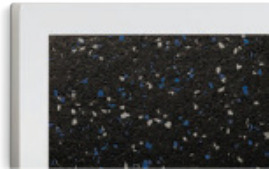

BLUE + GRAY

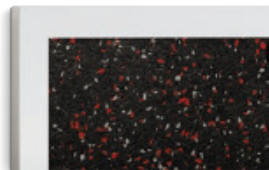

RED + GRAY

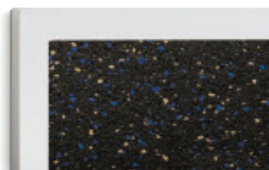

BLUE + TAN



## DTS SERIES

MODEL	SIZE (HxW)
8380404XX	4' x 4'
8380405XX	4' x 4'
8380406XX	4' x 6'
8380408XX	4' x 8'
8380410XX	4' x 10'
8380412XX	4' x 12'

# Edges Wrapped System (EW)

- Frameless tackable surface without exposed edges.
- Acoustical and noise cancelling qualities.
- Economical alternative to our many trim systems.
- Versatile applications attach by adhesives or fasteners to walls, doors, cabinets — any place you can imagine.

## VINYL ON STANDARD TACKBOARD

(1/2" LIGHTWEIGHT SUBSTRATE)

MODEL	SIZE (HxW)
8120404XX	4' x 4'
8120405XX	4' x 5'
8120406XX	4' x 6'
8120408XX	4' x 8'
8120410XX	4' x 10'
8120412XX	4' x 12'

## VINYL ON PREMIUM TACKBOARD

(1/8" CORK + 3/8" LIGHTWEIGHT SUBSTRATE)

MODEL	SIZE (HxW)
8121404XX	4' x 4'
8121405XX	4' x 5'
8121406XX	4' x 6'
8121408XX	4' x 8'
8121410XX	4' x 10'
8121412XX	4' x 12'

## FABRIC ON STANDARD TACKBOARD

(1/2" LIGHTWEIGHT SUBSTRATE)

MODEL	SIZE (HxW)
8123404XX	4' x 4'
8123405XX	4' x 5'
8123406XX	4' x 6'
8123408XX	4' x 8'
8123410XX	4' x 10'
8123412XX	4' x 12'

## FABRIC ON PREMIUM TACKBOARD

(1/8" CORK + 3/8" LIGHTWEIGHT SUBSTRATE)

MODEL	SIZE (HxW)
8124404XX	4' x 4'
8124405XX	4' x 5'
8124406XX	4' x 6'
8124408XX	4' x 8'
8124410XX	4' x 10'
8124412XX	4' x 12'



Platinum boards meet the gold level indoor air quality environmental standards of the Scientific Certification Systems



# Platinum Surface Colors

**Full spectrum favorites.** Choose from a wide variety of colors for your board surfaces. Writanium® markerboard and chalkboard colored surfaces offer high contrast and sharper definition. Our colored cork, vinyl and fabric tackboards come in a broad range of surface hues designed to complement contemporary or classic interior colors.

## Writanium® Markerboards

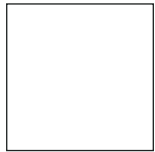

BRIGHT WHITE  
(STANDARD)

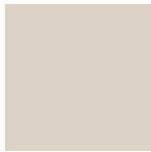

SOFT GRAY

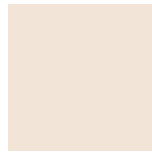

BEIGE

## Writanium® Chalkboards



BLACK  
(STANDARD)



GREEN



SLATE

## EnviroTack™

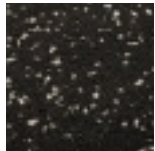

BLACK + WHITE

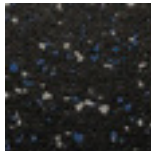

BLUE + GRAY

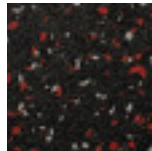

RED + GRAY



BLUE + TAN

## Natural Cork



NATURAL

## Colored Cork

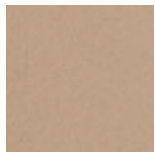

BLANCHED  
ALMOND

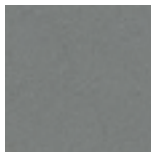

DUCK EGG

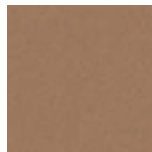

NUTMEG SPICE

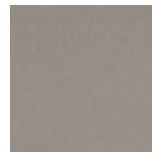

POTATO SKIN

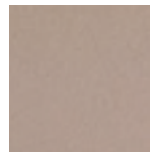

BROWN RICE

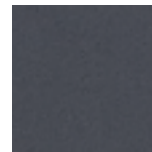

POPPY SEED

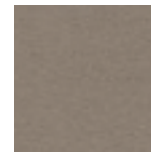

MUSHROOM

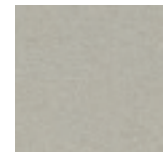

OYSTER SHELL



HOT SALSA



TANGERINE ZEST



FRESH PINEAPPLE



BABY LETTUCE



CINNAMON BARK



BLACK OLIVE



BLUEBERRY

*Note: Color swatches are printed approximations and actual color may vary. If exact match is required, please contact us to request a sample.*

## Vinyl - Bold Weave



ORIGIN



SILK

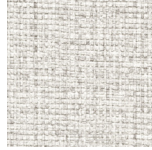

MUSLIN

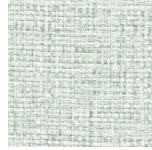

YARN

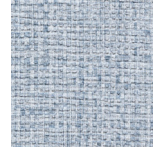

STITCH



CLOTH



CONTEMPORARY

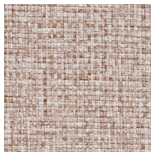

WEAVER

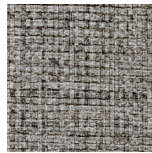

CRAFTSMANSHIP

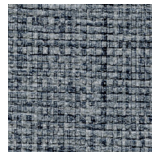

HANDLOOM



THREADS



COTTON

## Vinyl - Fine Weave



ATRIUM



MOONLIGHT



WINTER MIST



ROCKPORT



SEAMIST



DUCK



LIGHT DIONIS



GREY FEATHER



BREAKWATER



SCARBOROUGH



DESERT SHORE



SUNBERRY

## Fabric



SKY

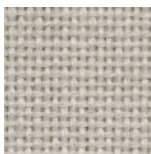

PEARL

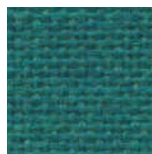

TEAL



SILVER PAPIER

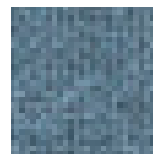

WEDGEWOOD

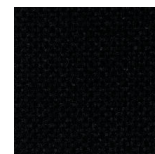

BLACK

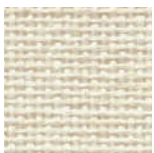

EGGSHELL



GREY MIX

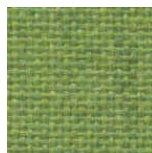

LIME

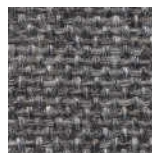

MEDIUM GREY

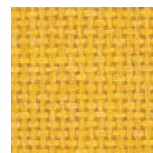

SUNSHINE

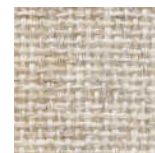

QUARTZ



*Platinum*   
VISUAL SOLUTIONS



1451 E. 6th Street, Corona, CA 92879  
800.498.2990 | 951.817.2200 | FAX 951.817.9900  
[www.pvsusa.com](http://www.pvsusa.com) | [info@pvsusa.com](mailto:info@pvsusa.com)

